



Your guide to altering your home in the

# Modern Character Area



In Letchworth Garden City

Revised June 2026

**Letchworth  
Garden City**  
Heritage Foundation

# Contents

<u>Introduction</u>	<u>3</u>
<u>Making changes to your home</u>	<u>4</u>
<u>The Character Areas</u>	<u>5</u>
<u>Modern Character Area</u>	<u>6</u>
<u>Rear extensions</u>	<u>7</u>
<u>Side extensions</u>	<u>9</u>
<u>Front extensions</u>	<u>10</u>
<u>Porches</u>	<u>11</u>
<u>Garage conversions</u>	<u>12</u>
<u>Loft conversions, dormer windows, rooflights &amp; sun tunnels</u>	<u>13</u>
<u>Chimneys &amp; flues</u>	<u>14</u>
<u>Garages - new or extended</u>	<u>15</u>
<u>External doors - new &amp; replacement</u>	<u>16</u>
<u>Windows - new &amp; replacement</u>	<u>17</u>
<u>Roofs, new roofs, alterations, re-tiling &amp; repairs</u>	<u>18</u>
<u>Alterations to external walls</u>	<u>19</u>
<u>External features</u>	<u>20</u>
<u>Hardstandings</u>	<u>21</u>
<u>Trees &amp; hedges</u>	<u>23</u>
<u>Sheds &amp; detached outbuildings</u>	<u>24</u>
<u>Satellite dishes, aerials &amp; radio aerials</u>	<u>25</u>
<u>Hedges, fencing, gates &amp; vehicular gates</u>	<u>26</u>
<u>Rainwater harvesting &amp; grey water recycling</u>	<u>27</u>
<u>Glossary</u>	<u>28</u>
<u>Contemplating changes?</u>	<u>31</u>

# The World's First Garden City

## Letchworth is Special

It is the world's first Garden City, advocated by Ebenezer Howard as a solution to the poverty and squalor of England's cities and towns in the late 1800's. Garden cities set out to achieve the perfect balance of town and country.

The approach of Howard's company to the ownership of land was special too: First Garden City Ltd insisted on retaining freehold ownership of its Estate. It did so in order to control developments on its land and create the necessary financial resources to fund future investment for the benefit of the town.

Later, the Leasehold Reform Act 1967, gave individual leaseholders the right to buy the freehold from the landlord. Many have taken up this option.

In Letchworth Garden City most lessees buying their freeholds are required to sign up to a Scheme of Management. Under this Scheme, permission is normally required before making external changes to Garden City homes.

This Scheme of Management has helped preserve the character of Letchworth by protecting the key features of individual houses and their setting.

There are many other examples of such schemes across the country. In the South East these include, Hampstead Garden Suburb, the Dulwich Estate and Grosvenor Estates, all introduced under the Leasehold Reform Act 1967.

## Please Remember

An approval under the Scheme of Management or under your lease confirms that the proposals comply with the Foundation's requirements on design and aesthetics and is not:

- A planning permission;
- Listed Building consent;
- A permission to build

### Also:

- Building Regulations approval, Party Wall Agreement and/or neighbours consent may be required;
- The Heritage Foundation cannot mediate, assist or formally determine on neighbour disputes

At the point of gaining quotations for the work, please refer the Contractors to these Principles.

# Making changes to your home

As freeholders of the Garden City Estate we operate a Scheme of Management.

All homeowners in Letchworth Garden City have a role to play in protecting the special nature of the Garden City.

In addition, many residents living in leasehold properties have covenants under which they are also required to obtain our consent for external works to their property.

We are committed to working with residents to preserve the appearance and character and to ensure that alterations are in keeping. Therefore, if you wish to make external changes to your Garden City home you need to apply for our consent. **(This requirement is separate from the permission required from the local authority under planning and listed building legislation and the building regulations).**

Works undertaken without our approval could lead to action being instigated, difficulty in selling your home or even legal action to remove the unauthorised works.

We use these Design Principles to help you and your representatives to understand the type of alterations that are likely to be acceptable.

Applicants are also invited to provide a Design Statement in support of their application.

When considering proposals for alterations we would support applications that reintroduce original designs and detailing that have been lost over time.

## We're Here To Help

Contemplating development?

Call us now on **01462 530 335**

email **home@letchworth.com**

Get in touch with our team before finalising your plans.

## Pre-application Advice

We have a dedicated team, on hand to support you through every step of the proposed development review process; in fact, we would be happy to help from the very start. The earlier you come to talk to us, the more guidance we can provide.

Whether your plans exist in your head or are hand drawn, we can discuss your ideas and help you develop a scheme that meets your needs, is sympathetic to your home and compliant with the Design Principles. We're happy to hold a meeting with you and your architect/agent for preliminary discussions.

# The Character Areas

As Letchworth Garden City was developed over several years, there is a clear difference in the style and character in parts of the town. This resulted in the introduction of defined Character Areas.

## 1. Heritage Character Area

## 2. Modern Character Area

There is a set of Design Principles for each character area. These have been developed considering the style and characteristics of specific homes and streets, rather than simply the age of the buildings.

Each area has been defined through a detailed examination of characteristics relevant to individual homes and streets, including the date the property was built, house style, detail and materials, road layout, parking, house orientation, the building line, trees and verges, front gardens, boundaries and density.

In addition, the design of some homes will differ from their Character Area. For example, where individual modern properties have been built within the Heritage Character Area, or where an older home lies within the Modern Character Area.

In all cases each home will be considered on its own merits, although the impact of alterations on the surrounding context as well as an individual property will be addressed.

To find out the Character Area your home is within, there is an online search tool at:

**[www.lechworth.com/your-home/before-applying](http://www.lechworth.com/your-home/before-applying)**

or call us on **01462 530335**.

### **Please be aware**

The purpose of the Design Principles is to provide assistance for applicants and their agents as to what may or may not be reasonably acceptable in certain circumstances. However, in view of the breadth of styles of property and street scene in the Garden City Estate, each case will be carefully considered on the specific circumstances of the property and its context. In all cases a high quality and considered design will be sought.

### **Please note**

A helpful glossary is provided on pages 28 to 30 explaining the building terms in this document.

# Modern Character Area

## **The Design Principles outlined in this publication relate to the Modern Character Area of Letchworth Garden City.**

The area includes a wide range of housing styles, with some specific areas having a unique generic style.

Many homes have open frontages set along wide roads.

### **Using the Design Principles**

The Design Principles have been developed to help you plan and implement any external alterations to your home, large or small.

Split into distinct sections, the Principles address a wide range of building changes, from extensions and hard-standings to windows and doors.

If you are contemplating making changes, it is important that you review all the relevant principles, bearing in mind an extension may also need to consider the Design Principles for other features such as windows and doors.

The principles generally indicate what is and is not acceptable when seeking to make alterations. However, each case will be considered on its own merits assessing the impact of proposals on the character and quality of the property and its context.

In all cases a high quality and considered design will be sought.

The Heritage Character Area Design Principles apply to homes in the award-winning Hartington Place and Ralph Swingler Place, developments.

# Rear extensions

**The later Modern Character Area homes were largely built to reflect the modern design concepts of the time but guided by the Garden City ethos.**

Homes range in size from small terraced houses to larger detached and semi-detached buildings as well as flats. There are examples of homes which have architectural qualities that are a valuable feature of the town. They largely share a common vision of creating an environment that links town and country - trees and gardens are an important element of this vision.

- The space between buildings is an important feature of the whole Garden City and shall be maintained
- Rear extensions shall complement the character of the original house, using the detailing and complementing materials, and have balanced proportions and scale
- Roof pitches can have a substantial impact on the character of the original house, therefore proposed roof pitches shall be consistent with the original roof design of the house
- Extensions that protrude past the side/gable wall of the original house are subject to the requirements for side extensions (See Side Extensions on page 9)
- The area and volume of the proposed extension shall be in proportion to the existing house and plot
- Design shall respond to and harmonise with the individual qualities of the host building and its setting. Therefore, in all cases high quality design will be encouraged, while poor design will be rejected, and alternative solutions sought
- An appropriate rear garden shall be provided to ensure that an adequate private amenity provision is retained, preventing a cramped or over-developed appearance
- Extensions shall not lead to an unacceptable loss of amenity to neighbouring occupiers. Windows in the flank of extensions that cause overlooking shall be avoided. As a guide, rear extensions shall also meet the light angle guidance, as well as the maximum depths included in these principles

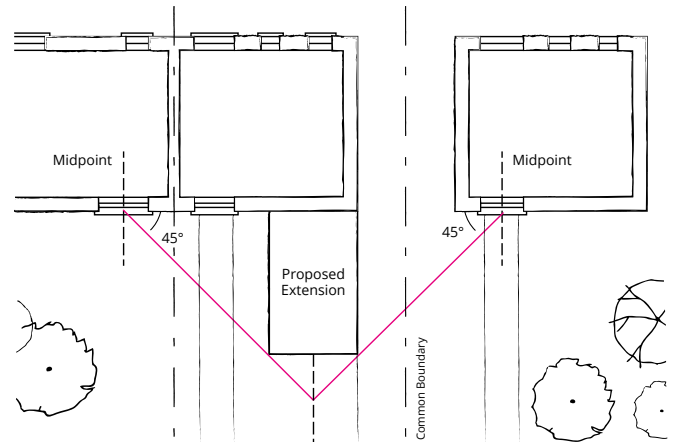

*45° extension rule*

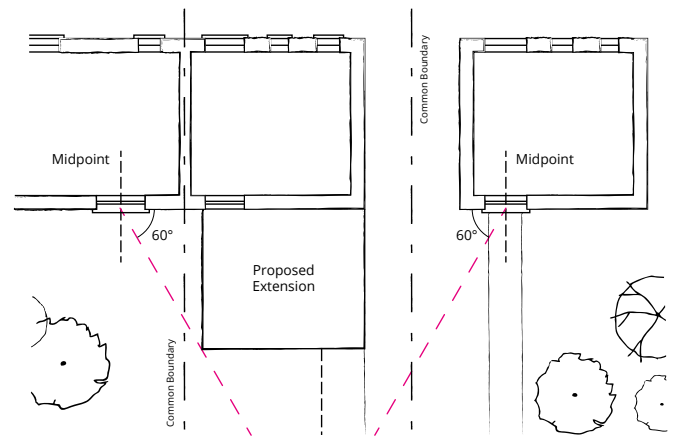

*60° extension rule*

## Detached Dwellings

- Ground floor and 2 storey extensions up to a depth of 5 metres from the original main rear building line of the house may be acceptable. When 2 storey extensions would have an impact on neighbouring properties, a reduction in depth and/or width may be required
- Extensions to houses on very large plots may exceed 5 metres from the original main rear building line, if it can be demonstrated that there is negligible effect on the neighbouring property and it is not detrimental to the character of the property or its setting
- The relationship between rear extensions on adjoining properties can create a poor appearance, in particular by reason of unsightly gaps

## Semi-Detached Dwellings

- Ground floor extensions up to a depth of 5 metres from the original main rear building line of the house may be acceptable
- Due to the likely impact on the neighbouring property, 2 storey extensions shall not normally exceed 3.6 metres from the original main rear building line. When 2 storey extensions have an impact on neighbouring properties, a reduction in depth and/or width may be required
- Ground floor extensions for the full width of the building may be acceptable
- To prevent unsightly dark narrow gaps between buildings that provide maintenance access, side walls of rear extensions shall either abut the boundary or provide an appropriate maintenance gap between buildings and rear extensions (a minimum of 0.6m). This does not override the requirement to comply with other legislation, such as the Party Wall Act

## Terraced Dwellings

- Ground floor extensions up to a depth of 3.6 metres from the original main rear building line of the house may be acceptable. A greater depth of extension will only be considered when it is demonstrated that it will not have an unacceptable impact on neighbouring properties, the remaining garden depth and the appearance of the existing property and its context
- Due to the likely impact on the neighbouring property, 2 storey extensions are not acceptable.
- Ground floor extensions for the full width of the building are not permitted
- To prevent unsightly dark narrow gaps between buildings that provide maintenance access between properties, side walls of rear extensions shall either abut the boundary or provide an appropriate maintenance gap between buildings and rear extensions (a minimum of 0.6m). This does not override the requirement to comply with other legislation such as the Party Wall Act

## Conservatories

- Conservatories shall be relatively modest in proportions and in all cases not exceed the Design Principles for extensions
- Conservatories are predominantly glazed structures. The glossary on page 28 provides a definition. If you are considering a non-glazed roof, the structure would then be an extension and will need to adhere to the advice on rear/side/front extensions
- Designs that create secret gutters between the conservatory roof slope and the existing house wall shall be avoided

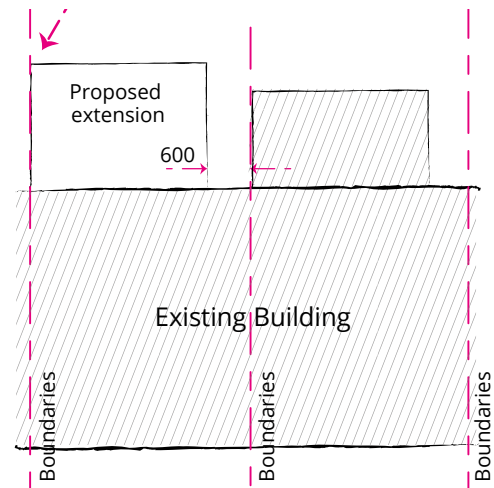

*Extension can abut the boundary if there are no existing buildings adjacent*

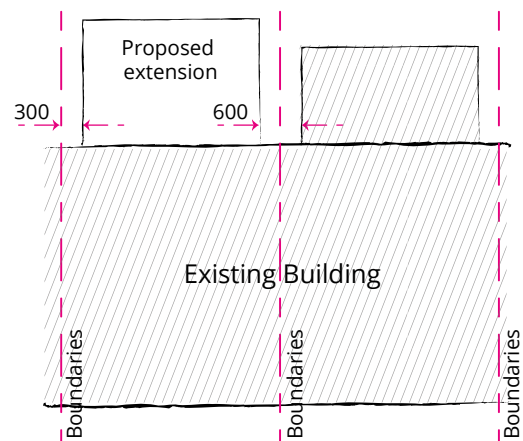

*Minimum distances of rear extensions from existing buildings and boundaries*

# Side extensions

**Many Modern Character Area homes retain the open characteristic of the Garden City including examples of sweeping access roads, in cul-de-sacs and around common open spaces.**

The spacing between individual houses or terraces and the views to the green gardens behind them reinforced the connection between the town and country. The challenge today is to maintain the distance between the neighbouring homes to help retain this character and the open feel:

- The width of side extensions can greatly impact on the original character of the home and the street scene – particularly the vistas between these homes
- It is preferable for extensions to be on the rear of the property as these normally have a reduced impact on the character of the context, therefore rear additions shall be explored in the first instance
- Side extensions shall be consistent with the character of the original house, utilising the detailing and matching materials, respecting the proportions and scale of the existing property
- Roof pitches can have a substantial impact on the appearance of a building and the street scene; therefore all proposed roof pitches and design of the roof and roof line shall be consistent with the original roof design of the house, unless it can be demonstrated that the extension does not damage the character and quality of the existing property and its context

## All Dwellings

- The area and volume of the proposed extension shall be subservient to and in proportion with the existing house and plot
- Ground floor extensions shall retain a 1 metre gap to the boundary
- To maintain the open feel and space around detached and semi-detached dwellings, the side walls of proposed 2 storey and first floor side extensions shall be a minimum of 2 metres from a boundary
- First floor extensions smaller than the footprint of the ground floor, can create a poorly proportioned and unbalanced building and generally will not be supported, unless it can be demonstrated that it would not be detrimental to the character and appearance of the existing property and its surroundings/locality

## Semi-Detached Dwellings

- Side extensions shall retain the identity of the original property and be visually subservient. This is normally achieved by having lower roof lines and being significantly set back from the front building line

## End of Terrace Dwellings:

- Side extensions will not normally be permitted unless it can be demonstrated that it will not damage the group value of the existing terrace and its overall surroundings

## Bungalows

- Ground floor extensions will only be accepted when they are of modest proportions and sympathetic to the appearance of the existing dwelling and its setting

# Front extensions

**Modern Character Area homes were designed in a range of styles and varied design details, but the majority retained the Garden City ethos of space and green vistas.**

The quality of the original design of these houses contributes to the special Letchworth Garden City street scene.

Adding elements, including extensions, to these façades can have an impact on these attractive street scenes, particularly on terraced and semi-detached houses. These proposals will therefore be carefully considered as they can detract from the architectural value of the original and alter the relationship within a group of houses by:

- Creating an unsightly or unduly prominent form of development;
- Disrupting the uniformity of the front building line;
- Disrupting the coherence of a group of semi-detached or terraced houses;
- Diluting the 'group value' of a run or cluster of houses

This is particularly the case with first floor extensions, which can have a serious impact on the original character of the house and the street scene.

## **Front extensions are discouraged**

It is preferable for extensions to be on the rear of the property as these normally have a reduced impact on the character of the property and its context; therefore, rear additions shall be explored in the first instance.

Proposals for front additions will not be supported unless it can be demonstrated that they will not cause harm to the appearance of the existing property or its group. In the rare circumstance that this type of extension is permitted, the following principles will apply:

- Front extensions shall be consistent with the character of the original house, utilising the detailing and matching materials, and have balanced proportions and scale;
- Roof pitches can have a substantial impact on the appearance of a building and the street scene; therefore, all proposed roof pitches and design of the roof and roof line shall be consistent with the original roof design of the house

Design shall respond to and harmonise with the individual qualities of the host building and its setting. Therefore, in all cases high quality design will be encouraged, while poor design will be rejected, and alternative solutions will need to be submitted.

## **All Dwellings**

- The area and volume of the proposed extension shall be subservient and in proportion with the host building, plot and street scene
- The design of front extensions shall relate well with the original and neighbouring houses and their setting
- Front extensions will not normally be acceptable if the existing frontage is less than 5 metres deep
- Extensions shall respect the balance and symmetry of a pair or group of houses
- **Semi-Detached Dwellings**
- Extensions that upset the balance or symmetry of a pair or group of houses are unlikely to be acceptable

## **Terraced Dwellings**

- Front extensions will not normally be permitted unless it can be demonstrated that they will not damage the group value of the existing terrace and its overall setting

## **Bungalows**

- Front extensions will be accepted only when they are of modest proportions and sympathetic to the appearance of the existing property and its setting

# Porches

**A porch is a small extension immediately adjoining the main (usually front) entrance door. Shall a design proposal include any accommodation such as a WC or cloakroom, please refer to the section on Front Extensions.**

Adding elements to the front of homes can impact on the existing property and its context, particularly so on terraced and semi-detached houses. These could detract from the architectural value of the original and alter the relationship within a group of houses by:

- Creating an unduly prominent form of development
- Disrupting the uniformity of the front building line
- Disrupting the coherence of a group of semi-detached or terraced houses
- Diluting the 'group value' of a run or cluster of houses

Porches shall complement the character of the original house and street scene, using materials that are in keeping with the existing property and have balanced proportions and scale.

Design shall respond to the individual qualities of the host building, plot size and its setting. Therefore, applications may still be refused consent on the grounds of inappropriate or poor design, even when other principles are complied with.

## Proposed Porches on the Front Elevation

- Front porches are acceptable when they already exist as an acceptable feature within the context and will not break up the symmetry of, or unbalance a group of properties
- They shall not normally extend more than 1.5 metres from the original front main building line (See Glossary on page 28)
- In some instances, such as on large houses with frontages over 8 metres deep, a deeper porch may be acceptable, where it is demonstrated that this will not harm the character of the existing property or in the case of terraced and semi-detached houses, the group of properties and their context

## Proposed Porches on Other Elevations

- The relationship to the side boundary shall be considered and an enclosed porch shall normally maintain a gap of at least 1 metre unless it can be demonstrated that the proposal will not lead to a cramped form of development or a 'terraced' impression

**Note: Reference shall also be made to the sections for the front, side or rear extensions.**

## Existing Porches

- Removal of original features such as open porches, canopies or tiled hoods can damage the original character of the property and will not normally be supported

# Garage conversions

**Homes in the Modern Character Area are characterised by contemporary detailing.**

Changes to the use of garages into habitable rooms can impact on the style and appearance of individual houses and create increased need for parking in front gardens.

When there is enough justification to support the conversion then it shall be normally ensured that:

- The property's frontage has capacity to provide at least two car parking spaces (standard size 2.4m x 4.8m); and
- The provision of the parking spaces complies with the requirements for hard-standings on page 21

The design criteria in these circumstances are:

- Retention of the garage doors is preferred, but if to be replaced by a window it shall match the style and proportions of the original windows and shall comply with the requirements for windows on page 13
- In some roads, there is a pattern of houses with garages and therefore garage doors need to be retained
- New windows to provide light and ventilation to the converted garages shall also comply with the requirements for windows on page 13
- Proposals to link a detached garage to the main house will only be supported when it is demonstrated that it will not diminish the views to the rear gardens or detract from the original design of the property

# Loft conversions, dormer windows, rooflights & sun tunnels

**Many Modern Character Area homes retain the open characteristic of the Garden City including examples of sweeping access roads, in cul-de-sacs and around common open spaces.**

This element will need careful consideration, as the addition of dormers, roof lights and roof alterations can have an impact on neighbours and the original character of the house.

A loft conversion is generally acceptable provided it does not alter the original roof design and ridge height. Roof lights can improve natural light and ventilation. However, any dormers and/or roof lights can have a significant visual impact and will be carefully considered.

- Loft conversions in bungalows shall normally be designed with all windows to the rear, as the street scene will be particularly sensitive to roofscape alterations

Dormers and roof lights in most cases shall be to the rear but might be permitted on the front elevation if they are an existing characteristic of the original dwelling and street scene. All dormers and rooflights shall meet the following requirements:

- An unacceptable increase in the number of dormer windows and/or rooflights; dimension appropriate
- Dormers shall reflect the style and appearance of the house and its context;
- Dormers shall be modest in relation to the area and slope of the roof and their scale shall not dominate or upset the balance of any building elevations or the street scene;
- Materials for dormer windows shall preferably match the original materials of the house. However, other materials may be acceptable if in keeping with the style of the property;
- Small openings for roof lights that do not negatively affect the overall composition of the building will normally be acceptable;
- Lantern type roof lights in flat roofs shall be a size that is proportionate to the roof area
- New dormers on the front of existing bungalows shall be avoided

# Chimneys & flues

**Chimneys are often used to establish balance on house façades. Chimneys are and shall remain common features that enhance the Letchworth Garden City roofscape.**

- Unless in exceptional circumstances, existing chimney stacks or pots shall not be removed
- Shortening of the stacks shall be avoided
- Adding inappropriate pots or flue terminals shall be avoided
- New chimneys will be acceptable if the proposed design, detailing, style and position is appropriate to the original house design and the street scene
- Replacement, prefabricated, or refurbished chimneys shall retain original details and features
- Metal flues for wood burning stoves may be acceptable if:
  - – Sited in an unobtrusive position so they do not impose on the street scene;
  - – It is a maximum of 1 metre high above the roof finish, or 0.6 metre above the roof ridge line;
  - – They have a silver finish where the dwelling has white painted or light features; or black, dark brown or stained or dark features or housed by a new chimney of an appropriate design and location
- We may require evidence that any new flue or stack conforms with Building Regulations

**You are advised to contact North Hertfordshire District Council to ensure that the new flue and chimney will not be harmful to you or your neighbours and complies with all statutory building requirements.**

# Garages - new or extended

**Most properties in the Modern Character Area were designed with some off-street parking, although often less than currently required.**

As car ownership has grown over recent years, there is a challenge in accommodating this feature while preserving the valuable asset of green street scenes, including front gardens, hedges and trees.

- New garages shall complement the original style of the house, including windows and doors
- New garages located behind the front building line of the existing house are strongly preferred and, in most cases, can assist in maintaining the green and open feel of the frontages
- In cases where the garage is to the front or adjacent to the property, a 1 metre gap shall be retained to the side boundaries unless it can be demonstrated that the proposal will not lead to a cramped or 'terraced' impression. (See Diagram 1)

If the garage is proposed to the rear of the existing house it may be sited directly abutting the boundary (see diagram) provided that:

- A 1 metre minimum wide access gap to the rear garden is provided
- The roof or gutters do not overhang the boundary
- It does not normally exceed 6m in length
- It will not have a significant impact on neighbouring properties including garden areas
- It is restricted to single storey
- It will not be visually prominent from a public place
- If not on the boundary, a gap of 0.6 metres shall be provided

Addition of a storey above garages to the front of a property will only be accepted where it is demonstrated that it will not damage the character of the existing property and its context and will not have an unacceptable impact on neighbouring occupiers, including garden areas.

A detached garage, along with any other outbuildings, shall not take up an excessive amount of the rear garden. Reference shall be made to page 24 regarding the total amount of garden area taken up by outbuildings.

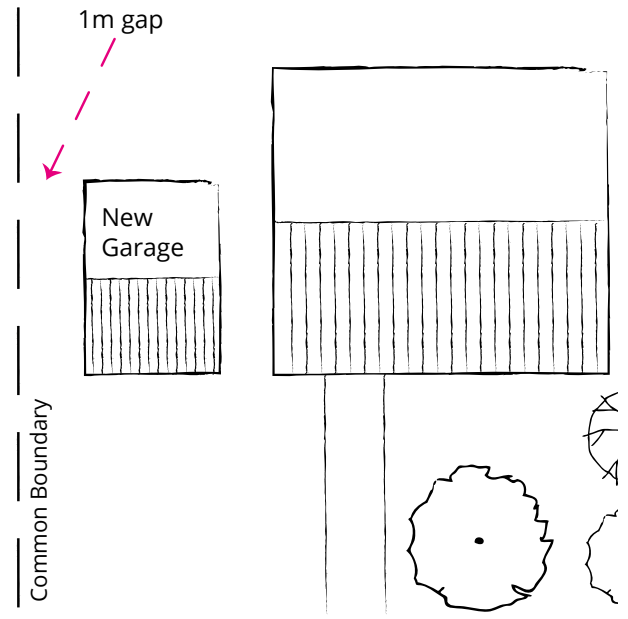

Diagram 1

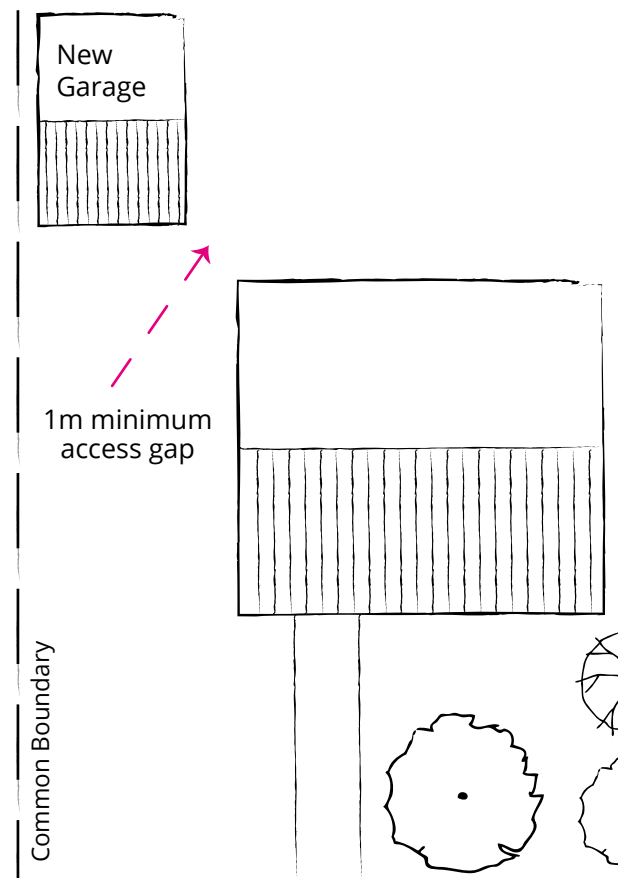

Diagram 2

# External doors new & replacement

**Homes in the Modern Character Area have diverse detailing arising from a different design approach and the use of different materials compared to earlier homes.**

A range of materials and designs are acceptable in the Modern Character Area.

Replacing an existing door with 1 of a matching design and materials helps preserve the character of the original design and street scenes of Letchworth Garden City.

- New and replacement doors shall normally match the original door design and complement the style of the house and the street scene
- The positioning and orientation of door openings shall relate to the original design

Door features shall normally adhere to the original design (e.g. canopies, hoods, lintels, glazing, double leaf etc.)

- Materials matching the original door (e.g. timber) are encouraged. Composite and uPVC doors will be accepted where it is demonstrated that the proportions and appearance will match those of the original door
- Stained or coloured glass may be acceptable if in keeping with the style and character of the original house design
- External doors shall be finished in a solid single colour to respect the character of the original house and its context

# Windows - new & replacement

## **Windows contribute significantly to the identity and value of individual and groups of houses and the street scene.**

Repair and restoration of original windows with materials matching the original design can help enhance the character of the homes.

The size, location and materials of windows on the façade of a house strongly influence the overall composition and character of a home. Changes can completely alter the character, particularly if the house is one of a group.

The group value of buildings is strengthened through a similarity in window type and colour, symmetry in the positioning of windows and adherence to the original proportions and design.

Careful planning of any changes is essential to ensure the integrity of the home and street scene, in which it sits.

- Replacement windows shall match the style and design of the original windows in the property
- A mix of materials in a single elevation will not be supported
- Windows shall remain open glazed if this was the original design
- Materials matching the original window (e.g. timber) are preferred, but a range of materials are acceptable
- External glazing bars or external leading are preferred where this was an original feature of the property
- Equal sight lines are preferred where this was an original feature of the property
- Where there are blocks of flats or houses that have been designed to be considered as one identity, replacement windows shall usually match the originals and include external glazing bars and/or equal sight lines, where these were original features
- The colour of all window frames and casements shall match the originals or, if the original colour cannot be identified, they shall relate to the original character of the property and the predominant colour of the street
- New window openings are only acceptable on the front elevation where it is demonstrated that this will not have a damaging impact on the existing property or its context
- Positioning, type and size of new openings shall be consistent with the original design of the property and style of the original windows

# Roofs, new roofs, alterations, re-tiling & repairs

## **The roofs of Modern Character Area houses use a range of traditional and modern designs and materials.**

- Changes to the style and height of a roof will not normally be acceptable
- Roof alterations shall reflect the original roof design and specifications
- Materials shall normally relate to the original style of the existing house

## **New Lean-to Roof on Extensions**

- Where the top line of lean-to roofs abut the wall, there shall be no cut-outs under windows

## **Re-roofing of Conservatories**

- Any proposal that alters an existing conservatory leading it to fall outside the definition for a conservatory (see Glossary), shall comply with the requirements for extensions included in this document. Imitation roof tiles on existing conservatories will not be accepted where they do not match the style and pitch of the existing house, although a lead or imitation lead treatment may be acceptable, where it respects the profiling of the existing conservatory

# Alterations to external walls

## **Homes in the Modern Character Area continue the tradition of using innovative building materials.**

These materials have become a distinctive trait of the Garden City and are one of the factors that create cohesion and character in neighbourhoods and buildings. Groups of buildings, that were designed and built together, are particularly vulnerable to changes of colour on façades - disrupting the sense of unity.

Many homes were originally finished with unpainted rendering and continue to create unity in groups of houses and in the street scene. The retention of these homes in their original state is an important part of retaining the quality of the street scene.

External painting of properties that have previously not been painted, such as brickwork or pebble dash exteriors, is discouraged and will only be supported if:

- It can be demonstrated that this would have a beneficial impact on the street scene;
- There are exceptional local circumstances;
- It will not damage the character of the property or its context

Exposed brickwork shall not be painted.

Bricks, joints and mortar of new brickwork shall match the original brickwork as closely as possible.

Painted render shall normally be repainted in the original colour.

If the original colour cannot be identified, a neutral colour shall be used that maintains cohesion within groups of buildings, street scenes and neighbourhoods.

Artificial cladding of properties is subject to separate guidance (see External Wall Insulation on Page 19).

# External features - Wall insulation, guttering & pipes & balconies.

## External wall insulation

External wall cladding can also have a negative impact on the appearance and character of a building.

Applying wall insulation externally can cover up important features and detailing, for example; string courses, window head and sill detailing, cornicing and decorative plaques.

Even the appearance of a relatively plain house can be affected by deeper window and door reveals.

Current external wall cladding systems are approximately 50mm thick when applied to a single house in a pair of semi-detached, a terrace or a group, the effect can be detrimental to the appearance and cohesion of the group.

External wall cladding can also have a negative impact on the appearance and character of a building and will normally be resisted.

Many modern Character Area homes have cavity walls and insulating the cavity is the best option to improve insulation.

## Guttering and pipes

- Careful positioning of replacement guttering, soil, vent and downpipes and the use of the original colour, can help to minimise the impact on the street scene
- New soil pipes to the front elevations shall normally be avoided.

## Balconies

Balconies may be acceptable but can upset the balance and scale of buildings and therefore the design shall be carefully considered

- The design would need to reflect the size and design of the existing house
- All balconies shall generally be located at the rear of the building
- 'Juliet' balconies are generally acceptable
- Full balconies which create an amenity leisure space at a first-floor level or higher may be acceptable, but regard to the privacy of the neighbours will be a major consideration

# Hardstandings

## **The materials used shall be carefully considered.**

The principles of the Garden City attempted to achieve a balance between these town and country living.

The natural green and leafy assets of Letchworth Garden City rely on mature street trees, green verges and in particular green front gardens. However, with modern living has come the need for car parking - a requirement not envisaged by the original designers. The tension between maintaining that green environment while accommodating car ownership can be challenging.

- The retention of a minimum of 50% soft planted landscaping in front gardens helps to maintain the green character of the Garden City and allows for natural water absorption through the soil
- Good design is crucial when planning hard-standings. There are many innovative and creative solutions which achieve the 50% of the frontage as green rule
- When creating hard-standings on front gardens, at least 50% of the original frontage area shall normally be maintained as soft landscaping, free of car parking, footpaths, bases for bin storage etc
- For smaller plots (less than 6 metres wide) the 50% restriction may not prove possible. Runners may be an acceptable option when there is:
  - A depth of at least 5 metres between the front building line and the front boundary
  - Limiting hard landscaping to two 1 metre wide runners separated by a 1 metre gap of low planting; and
  - Provision for substantial landscaping
- For frontages exceeding 100 square metres, the hardstanding area shall be no greater than 50 square metres (excluding an access driveway no wider than 3 metres)

- A Hertfordshire County Council approved crossover and dropped kerb is usually required. Works will not be issued with a Final (Plan) Approval until the crossover and dropped kerb are constructed
- Very small front gardens with frontages less than 5 metres deep will not be suitable for a hardstanding, as a standard parking space (2.4 metres x 4.8 metres) cannot be accommodated

Although gravel is not acceptable for soft landscaped areas, it may be used for hard-standings, but shall include measures to stop it spilling onto the highway.

Porous materials and permeable paving that reduce the impact of surface water run-off into water courses are strongly encouraged.

Neutral coloured concrete block pavements are acceptable; patterns, motifs or symbols shall not be incorporated.

Artificial grass is not supported on property frontages.

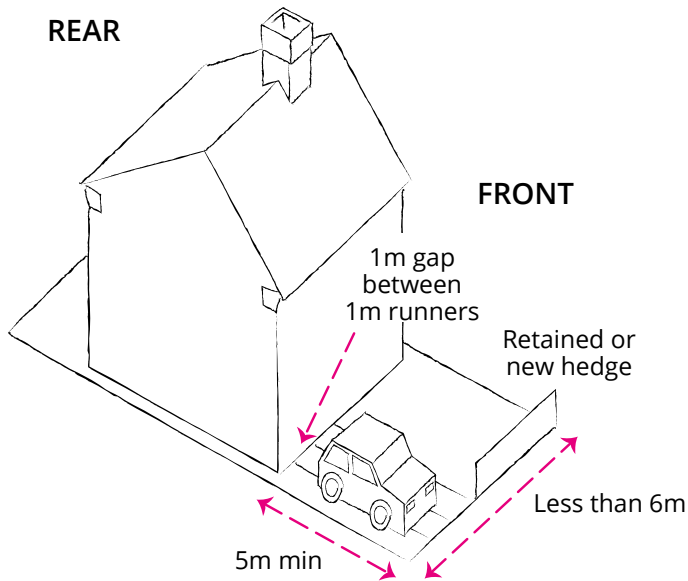

*Extended parking for narrow plots*

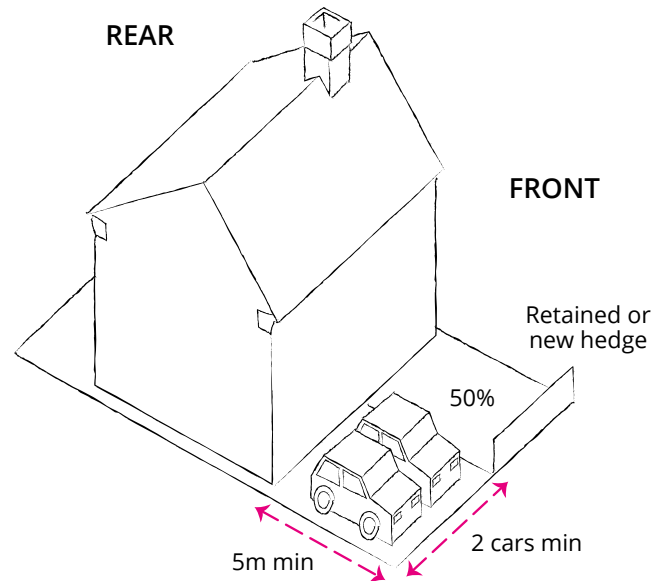

*Extended parking for wide plots*

**Something to note: Many properties in the Modern Character Area have no capacity for on-site parking.**

It is not compulsory to build the required parking spaces at the time of adding an extension, but consideration needs to be given to the need to provide two parking spaces.

To reduce surface water pressure on drains, a soakaway underneath the paved area of hardstanding is encouraged.

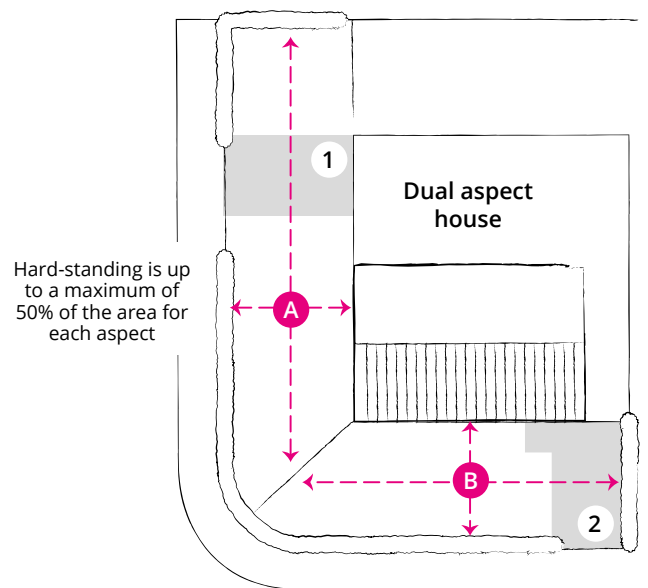

*Hard-standings*

# Trees & hedges

**Letchworth Garden City's unique place in architectural and urban history is intimately related to the creation of rural qualities within an urban environment.**

Mature trees and hedges along roads and in gardens and parks contribute significantly to the prominent green and natural character of the Garden City.

Preserving existing trees and hedges or replacing trees that are becoming sick or hazardous is essential to preserving Letchworth's green vistas and gardens. Permission is required to remove trees and hedges and an application must be made to the Heritage Foundation.

In parts of the Modern Character Area developments have been designed with open frontages and we wish to see these retained.

- Existing trees shall not be removed unless there is a proven justifiable cause
- Before agreeing to the removal of a tree or hedge, we would expect the management of the tree to have been first considered
- If approval is granted to remove a tree, an appropriate replacement will be required
- When proposing new or replacement trees or hedges, native species will be encouraged. Fast growing non-native species, such as Leylandii, are not acceptable
- When proposing alterations to a property, protection of existing trees and hedges will be an important consideration and the implications of proposed works on existing trees, including on neighbouring properties, shall be included in your applications.

**Please note that some works may require prior approval from North Hertfordshire District Council, which you are recommended to contact before starting.**

# Sheds & detached outbuildings

**A key principle for the Garden City is to ensure homes had enough associated garden space to reinforce the rural environment.**

Detached outbuildings include sheds, greenhouses, garden rooms, playrooms, climbing frames, tree-houses or ancillary accommodation.

These buildings shall be in scale with the green space available.

- Outbuildings shall be located in rear and not front gardens
- Outbuildings shall not detract from the character and quality of the existing property or its context
- An outbuilding in the rear garden up to 6 square metres in area and 2.2 metre ridge height will not require consent unless other outbuildings exist on the plot
- Outbuildings will not normally be acceptable if they exceed 10% of the area of the rear garden, free of buildings, to a maximum of 20 square metres and/or over 3 metres in height
- Outbuildings that exceed these dimensions may be accepted if their size is not out of proportion to the house and they do not dominate the rear garden or have a significant impact on the neighbouring property, including its garden
- More than 1 shed, or outbuilding may be acceptable, but the cumulative area shall not be more than 10% of the area of the rear garden and a maximum of 20 square metres
- Any outbuilding shall be at least 0.6m from any boundary
- The use of outbuildings for any commercial activity may require a Business Licence from the Heritage Foundation and possibly planning permission from North Hertfordshire District Council

## **Climbing frames and tree houses**

The height of platforms on children's play equipment, tree houses and other structures can cause privacy concerns for neighbours. The design must therefore give due respect to garden size, proximity to boundaries and the privacy of neighbouring properties and gardens.

## **Annexes and accommodation**

If the outbuilding is required to provide accommodation, you are advised to contact the Heritage Advisory Service for further guidance. A self-contained or separate unit of accommodation may require a separate approval under the terms of your lease or Scheme of Management.

For further information, please refer to the Design Principles Annex Design Guidance.

# Satellite dishes, aerials & radio aerials

**Adding satellite dishes, TV aerials and radio masts can upset the symmetry of a house, particularly if added to the front façade.**

Consent is not required for fitting a dish if it is no greater than 60cm in diameter, however, the following comments shall be taken into consideration:

- Satellite dishes shall be on the rear of the house unless a signal cannot be received;
- Discreet locations must be considered; (see diagram)
- Only 1 dish per property

Consent is required for dishes on front elevations:

- With a diameter greater than 60cm on front or prominent walls

Consent will not normally be given for dishes:

- With a diameter greater than 60 cm on front or prominent side walls
- That are in a colour not appropriate to the existing house and street scene
- More than 80cm in diameter

**More than 1 dish on a property will not be accepted.**

**Redundant dishes shall be removed.**

On apartment blocks a communal dish will be encouraged, rather than individual dishes for each flat.

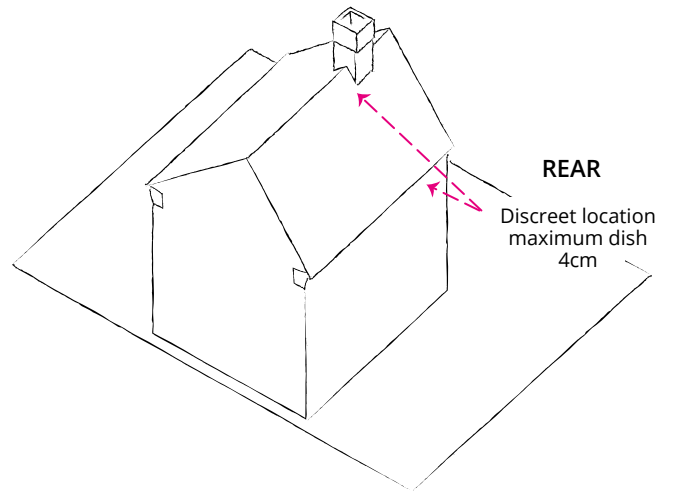

*Satellite dish positioning*

# Hedges, fencing, gates & vehicular gates

**Many of the Modern Character Area homes were designed with open frontages creating an open and airy public realm and views through the development, whilst some earlier houses had modest front hedges and/or low fences.**

This feature enhances the links to the rural and green surroundings and plays a part in the biodiversity of the Garden City. In many cases growing large hedges and building high fences and walls can be detrimental to this characteristic of the street scene.

- Boundaries to the highway shall match the predominant frontage boundary treatments. Hedges or fences to highway boundaries will be resisted in streets that were planned to have open frontages
- Existing hedges at the front shall normally be retained and their protection will be an important factor when considering alterations
- Heights and types of frontage hedges and/or fences shall reflect those on the same street, but as a general guide, they shall normally have a maximum height of 1 metre
- Privet, box and beech are the recommended varieties of hedging. Other suggested hedging plants are; berberis, hornbeam, Ionicera nitida and yew
- Conifers and fast-growing non-native species such as Leylandii shall be avoided
- Existing pedestrian gates shall normally be retained.
- Close boarded or woven type fences are not normally permissible on frontages but are acceptable on the rear garden boundaries
- If a hedge dies, it shall be replaced using suitable hedging plants, to be agreed
- **Hertfordshire Highways may have requirements on maximum heights if it affects traffic visibility**
- Close boarded or woven type fences that are on the rear garden boundaries, and are under 2 metres in height, do not require consent

**Vehicular Gates on to a street are not a common feature of Letchworth designs.**

Vehicular gates are not generally appropriate but may be acceptable in some circumstances, including if they are;

- Located in tree lined streets with wide verges
- Part of the original concept for the area;
- Not detrimental to or dominate the appearance of the house or the character of the street scene;
- Set behind the boundary hedge;
- Less than 3 metres in width and 1 metre in height;
- In a neutral colour;
- Gates should not open over a highway
- At least 6.5 metres from the front/building line

## **Please be aware**

Hertfordshire Highways approvals for dropped kerbs have specific requirements related to the visibility splays and enough depth on site for a car to park. Installing gates could prevent these criteria from being met.

# Rainwater harvesting & grey water recycling

**Re-using rainwater and recycling grey water can make a positive contribution to sustainable living, embraced by Letchworth Garden City pioneers.**

Finding a balance between sustainability and aesthetics can be challenging. Underground tanks can create ideal water storage conditions while the location of bulky water containers needs careful consideration. There are, however, sympathetic water butts available, which have less of an impact.

- Design shall complement the overall character of the building
- Size of the storage area shall not dominate the existing house

# Glossary

## A

### **Artificial Cladding**

External wall cladding manufactured to represent original wall finish materials such as rendering or brickwork; usually to provide additional insulation

### **Artificial Grass**

Plastic matting is a surface treatment used externally to mimic grass

## B

### **Bargeboard**

A protective and/or decorative board fixed to protruding roof timbers at the sloping edge (verge) of a pitched roof

### **Bi-Fold Doors**

Doors with multiple leaves (casements) that open by sliding and folding

### **Bonnet Hip**

Utilises an angular or 'saddle' shaped tile

### **Boundary**

The line that determines the limit of a property and usually delineates the separation of a property from the neighbouring property

### **Building Footprint**

The area of ground covered by a building

### **Building Line**

The line defined by the main front wall of buildings

## C

### **Casement**

(See Window Casement, Sash or Light)

### **Composite Door**

A door that is constructed of a variety of materials; the outer skin is usually moulded glass reinforced plastic (GRP) which covers timber reinforcing sections and foam insulation.

They are very strong and secure. They are designed to replicate the style and proportions of timber doors, but due to the materials used they do not readily fade or discolour and require minimal maintenance

### **Conservation Type Rooflight**

A rooflight recessed into the plane of the roof tiles and therefore not significantly proud of the roof finish. Usually with a black or dark grey finish

### **Conservatory**

A structure that conforms to the following:

- At least 50% of external wall area formed from translucent materials (not including walls within 1 metre of boundary)
- At least 75% of roof area formed from translucent materials.
- Be at ground level
- Be effectively thermally separated from the main part of the dwelling

## D

### **Dormer (Window)**

A construction with a window that projects from a sloping roof

### **Dummy Transom**

A glazing bar that is deeper than usual to represent a transom

## E

### **Eaves**

The construction at the foot of a sloping roof

### **Energy Performance Certificate (EPC)**

This rates the energy efficiency of the building between A (most efficient) to G (least efficient)

### **Energy Rating (for appliances)**

A tool to help customers compare appliances energy performance between A to D

### **Equal Sight Lines**

Non-opening casements or sashes installed into the fixed panes of a window to give equal or balanced glass lines

### **External Glazing Bars**

Mock glazing bars fitted to the external face of the glass in a window or door that simulate true glazing bars

### **External Leading**

Lead strips fixed to the external face of the glass in a window or door, to simulate a leaded light

# Glossary

## F

### **Fanlight (in a window)**

Opening upper casement of a window which hinges at the top.

### **Flush Casement (window)**

Opening casement (sash) that closes into the window frame and finishes flush with the face of the window frame

### **Frontage**

The area of land between the front building line and the boundary to the public highway

## G

### **Gable**

A triangular shaped vertical wall of a building directly under the roof

### **Glazing Bars**

Small bars forming the framework that support smaller multiple glass panes within a window casement or glazed section of a door

### **Grey Water**

Waste water that is generated from domestic activities such as laundry, dishwashing and bathing, which can be collected and recycled on-site for use such as garden watering

## H

### **Habitable Room**

Bedrooms, lounges, dining rooms, studies and other reception rooms in a house

### **Half Round Ridge Tiles**

A semi-circular roof tile used to finish the ridge

### **Hardstanding**

An area finished in concrete, stone, bricks, blocks, tarmac or gravel

### **Hard Landscaping (or Hardscape)**

Ground areas finished in concrete, stone, bricks, blocks, tarmac or gravel

### **Hipped Roof**

A roof where all of its sides are sloping i.e. with no gable end

## Hip

The external angle formed by the meeting of two sloping sides of a roof

### **Hopper Head**

An open topped receptacle connected to the top of a rainwater down pipe, which receives rainwater from a roof situated behind a parapet wall

## I

### **Internal/Mock Glazing Bars**

Decorative strips fixed between the double-glazing panes, to represent glazing bars

### **Internal Leading**

Decorative strips fixed to an internal face between the double-glazing panes, to represent a leaded light

## L

### **Leaded Lights**

Glazing made up of small panes of glass joined together by lead beading traditionally known as 'lead comes'

### **Lead Lined Valley (Gutter)**

The roof tiles are cut back at an angle to form the channel, which is lined with lead to form a gutter

### **Lifetime Homes**

A series of design criteria to make homes adaptable for lifetime use

### **Light**

A glazed section of a window

### **Lintel**

The structural element supporting the masonry above a door or window opening

## M

### **Mullion**

A vertical frame element that divides the window into individual casements

## O

### **Open Eaves**

Where the feet of the rafters are left exposed, with no fascia or soffit boards

# Glossary

## P

### **Paviour**

A small brick sized block or slab for surfacing hardstanding's etc.

### **Parged Verge**

Top of a gable wall sealed with mortar at its junction with the roof finish overhang, when there is no bargeboard

### **Photovoltaic (PV) Panel**

A panel (made up of many PV/Solar cells), usually fixed to a roof slope, that creates electricity from sunlight. (Not be confused with Solar Thermal Panel)

### **Picket Fence**

A traditional low (1-metre-high maximum) timber fence using vertical panes (boards) with gaps between each pale; sometimes called a 'palisade' fence

## S

### **Sash**

(See Window Casement or Sash)

### **Sett**

A rectangular or square small module paving stone

### **Soft Landscaping (or Softscape)**

Areas of planting e.g. flower beds, borders and lawns

### **Solar Thermal Panel**

A panel usually fixed to a roof slope that warms water using the heat of the sun (not to be confused with PV Panel)

### **Sprocket (Roof)**

A wedge-shaped piece of wood fixed to the foot of each rafter, to create a shallower pitch at the lower part of the roof

### **Storm, Storm-proof or Lipped Casements (Window)**

An opening casement (sash) that overlaps the face of the window frame when closed

### **Swept Valley (Gutter)**

Formed by special tapered tiles

## T

### **Transom**

A frame element that divides a window horizontally, usually under a fanlight casement

## U

### **Under Cloak**

The support (tiles or building board) for the mortar sealing on a parged verge

## V

### **Valley (Gutter)**

Horizontal or sloping channel, at the internal intersection between two roof slopes

### **Verge**

The junction where the roof finish overhangs the gable wall

## W

### **Window Casement or Sash**

Usually the opening part of the window, but can be fixed as a 'dummy' casement or sash, to create equal sight lines

## Contemplating changes?

We're here to help, call us now  
on: 01462 530335

Planning home alterations can be complex and stressful. The Heritage and Stewardship team are happy to provide pre-application advice to develop a scheme that meets your needs, is sympathetic to your home, and complies with the Design Principles.

Once your application is submitted, it will be assigned to a team member who will be your consistent point of contact until the conclusion.

All advice is free unless the works have been carried out without Consent, in which case a fee is charged for administering the retrospective application.